

Helical Pier Foundation System

U.S. Patents 5,011,336; 5,120,163; 5,213,448

Technical Manual

Contents

- Helical Pier Foundation System
 - History
 - Research and Development
 - Advantages
- Theory of Foundation Anchor Design
 - Soil Mechanics
 - Shallow and Deep Helical Pier Foundation Systems
 - Bearing Capacity Theory
 - Cohesive and Non-Cohesive Soils
- Installation Torque vs. Anchor Capacity
- Product Specification
 - Lead and Extension Section Lengths
 - Helix Areas
 - Helix Configuration
 - Helical Pier Foundation Systems ratings (table)
 - Corrosion
 - Slenderness Ratio/Buckling
 - Application Guidelines
 - Design Example
 - Specification References

SPEC DATA
PROGRAM PARTICIPANT

BOCA ES
Report No. 94-27

RADCO
CERTIFICATION • LISTING
TESTING • INSPECTION
I.C.B.O. Listed
Report No. ER5110

LISTED
SBCI
PST&ESI
Report No. 9504

See our catalog in Sweet's,
on Sweet's CD
and website,
McGraw-Hill, Inc.

HUBBELL
POWER SYSTEMS, INC.

CHANCE
www.abchance.com

ISO 9001:2000



Certificate No. 001136

HELICAL PIER FOUNDATION SYSTEMS

History

The earliest known use of an anchor foundation was for the support of lighthouses in tidal basins around England. A blind English brickmaker, Alexander Mitchell, is credited with design of a “screw pile” for this purpose in 1833. The use of the “screw pile” was apparently successful, but advancement of the helix-plate foundation did not progress.

In the 1950s, the A.B. Chance Company introduced the Power-Installed Screw Anchor (PISA®) for resisting tension loads. The anchor found favorable, widespread acceptance. This anchor consists of a plate or plates, formed into the shape of a helix or one pitch of a screw thread. The plate is attached to a central shaft. The helix plate has its characteristic shape to facilitate installation. Installation is accomplished by applying torque to the anchor and screwing it into the soil. The effort to install the anchor is supplied by a torque motor.

Research and development

With the development of the tension screw anchor, came the use of the same or similar devices to resist compression loads. Thus, screw pile foundations came into greater use. Various sizes and numbers of helices have been used with shafts of varying sections to provide foundations for different applications. In the past 40 years, projects that have utilized screw pile foundations include electric utility transmission structures, Federal Aviation Administration flight guidance structures, pipeline supports, building foundations, remedial

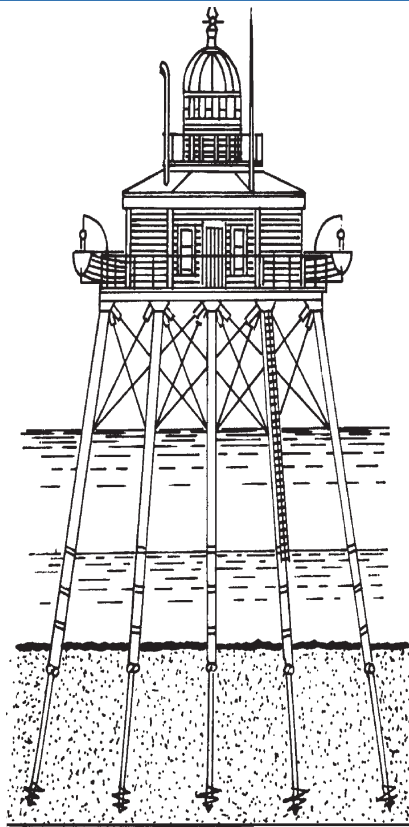

underpinning, streetlights, walkways in environmentally sensitive areas and many others.

Torque capacities of available installation equipment have increased over the past years. Hydraulic torque motors in the 3,000 to 5,000 ft.-lb. (4.0 to 6.8 kN-m) range have increased to the 12,000 to 15,000 ft.-lb. (16 to 20 kN-m) range. Mechanical diggers now extend the upper range to 50,000 ft.-lb. (68 kN-m) or more. “Hand-held” installers have expanded the available equipment in the lower range of torque, with a capacity up to 2,500 ft.-lb (3.4 kN-m). Though called “hand-held,” these installers are hand-guided while a torque bar or other device is used to resist the torque being applied to the screw pile foundation.

As suggested earlier, the screw pile foundation may be utilized in various forms. The lead section (i.e., the first part

to enter the ground) may be used with one or more helices (generally, four is the maximum) with varying diameters in the range from 6 to 14 inches (15 to 36 cm). Extensions, either plain or with additional helices, may be used to reach deep load-bearing strata. Generally, eight is the maximum number of helices used on a single screw pile foundation. The shaft size may vary from 1½" (3.8 cm) square solid bar material to 10" (25 cm) diameter pipe material. The number and size of helices and the size and length of shaft for a given application are generally selected based on the in-situ soil conditions and the loads that are to be applied.

Advantages

The screw pile foundation system is known for its ease and speed of installation. Installation generally requires no removal of soil, so there are no spoils to dispose of. Installation causes a displacement of soils for the most part. However, in the case of a foundation with a pipe shaft, some soil will enter the interior of the pipe until it becomes plugged. Installation equipment can be mounted on vehicles when required. The installation of a screw pile foundation is for practical purposes vibration free. These features make the screw pile foundation attractive on sites that are environmentally sensitive. Installations near existing foundations or footings generally cause no problems. However, the screw pile foundation generally cannot be installed into competent rock or concrete. Penetration will cease when materials of this nature are encountered.

THEORY OF FOUNDATION ANCHOR DESIGN

Soil mechanics

Throughout this discussion we will concern ourselves with the theories of soil mechanics as associated with foundation anchor design. The mechanical strength of the foundations will not be considered in this section as we expect foundations with proper strengths to be selected by the design professional at the time of design. For this discussion, we assume the mechanical properties of the foundations are adequate to fully develop the strength of the soil in which they are installed. Although this discussion deals with the foundation anchor, the design principles are basically the same for either a tension or compression load. The designer simply uses soil strength parameters above or below a helix, depending on the load direction.

Shallow and deep foundation anchors

Two modes of soil failure may occur depending on helix depth: One is a shallow failure mode and the other is a deep failure mode. Foundations expected or proven to exhibit a specific mode are often referred to as “shallow” or “deep” foundations. The terminology “shallow” or “deep” refers to the location of the bearing plate with respect to the earth's surface. By definition, “shallow” foundations exhibit a brittle failure mode with general eruption of the soil all the way to the surface and a sudden drop in load resistance to almost zero. With “deep” foundations, the soil fails progressively, maintaining significant post-ultimate load resistance, and exhibits little or no surface deformation. The dividing line between shallow and deep foundations has been reported by various investigators to be three to eight times the

foundation diameter. Chance Company uses five diameters as the break between shallow and a deep foundation anchors. The five-diameter depth is the vertical distance from the surface to the top helix. The five-diameter rule is often simplified to 5 feet (1.5 m), minimum.

Any time a foundation anchor is considered, it should be applied as a deep foundation. A deep foundation has two advantages over a shallow foundation:

1. Provides an increased ultimate capacity.
2. Failure will be progressive with no sudden decrease in load resistance after the ultimate capacity has been achieved.

Bearing capacity theory

This theory suggests that the capacity of a foundation anchor is equal to the sum of the capacities of individual helices. The helix capacity is determined by calculating the unit bearing capacity of the soil and applying it to the individual helix areas. Friction along the central shaft is not used in determining ultimate capacity. Friction or adhesion on extension shafts (but not on lead shafts) may be included if the shaft is round and at least $3\frac{1}{2}$ " (8.9 cm) in diameter.

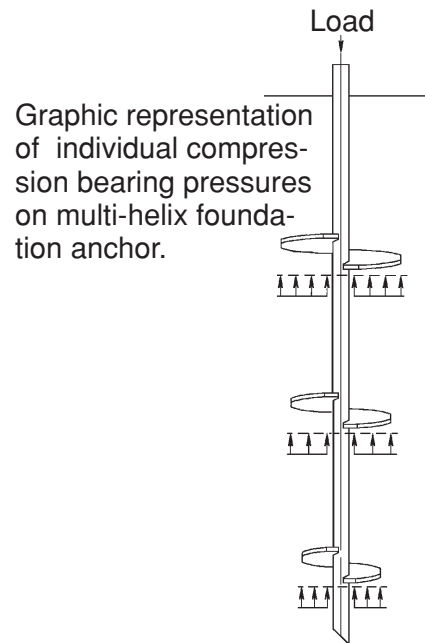

Graphic representation of individual compression bearing pressures on multi-helix foundation anchor.

A necessary condition for this method to work is that the helices be spaced far enough apart to avoid overlapping of their stress zones. Chance Company manufactures foundations with three-helix-diameter spacing, which has historically been sufficient to prevent one helix from significantly influencing the performance of another.

The following reflects the state-of-the-art for determining

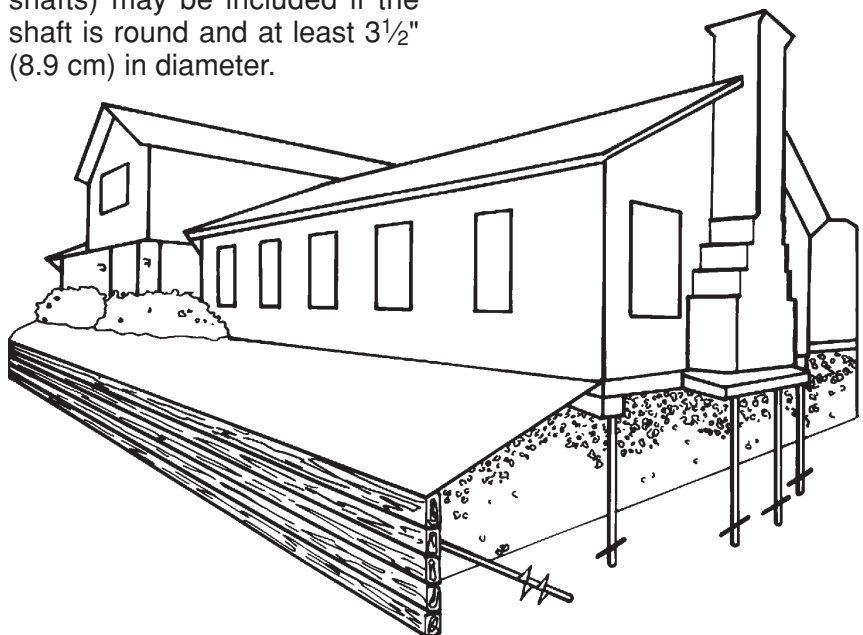

THEORY OF FOUNDATION ANCHOR DESIGN (continued)

deep multi-helix foundation capacities as practiced by Chance.

Ultimate theoretical capacity of a multi-helix foundation equals the sum of all individual helix capacities, see Equation A. To determine the theoretical bearing capacity of each individual helix, use Equation B.

Equation A:

$$Q_t = \sum Q_h$$

Where:

Q_t = total multi-helix anchor capacity

Q_h = individual helix bearing capacity

Equation B:

$$Q_h = A_h (9c + q N_q) \leq Q_s$$

Where:

Q_h = Individual helix bearing capacity

A_h = projected helix area

c = soil cohesion

q = effective overburden pressure

N_q = bearing capacity factor (from the graph, next page)

Q_s = upper limit determined by helix strength

Projected helix area (A_h) is the area projected by the helix on a flat plane perpendicular to the axis of the shaft.

Cohesive and non-cohesive soils

Shear strength of soils is typically characterized by cohesion (c) and angle of internal friction “phi” (ϕ), given in degrees. The designation given to soil that derives its shear strength from cohesion is “cohesive” and indicates a fine-grain (e.g., clay) soil. The designation given to soil that derives its shear strength from friction is “non-cohesive” or “cohesionless” and indicates a

Bearing Capacity Factor for Cohesionless Soils

Figure 1

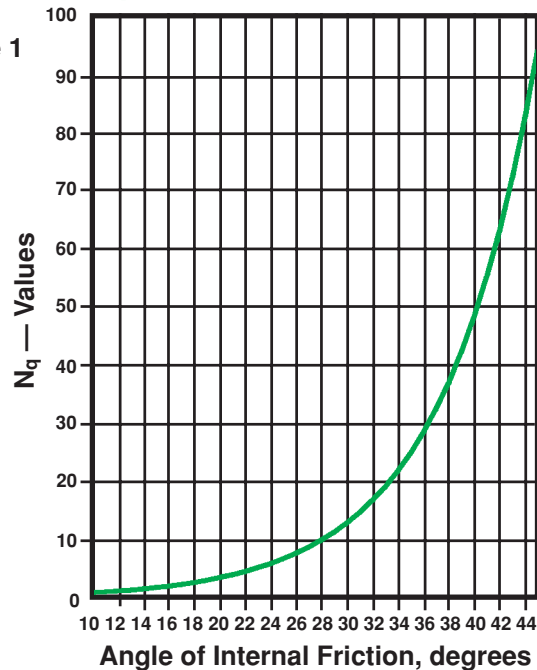

granular (e.g., sand) soil.

The product “ $9c$ ” from Equation B is the strength due to cohesion in fine grain soils, where 9 is the bearing capacity factor for cohesive soils. The product “ qN_q ” from Equation B is the strength due to friction in granular, cohesionless soils. The bearing capacity factor for cohesionless soils (N_q) may be determined from Figure 1. This factor is dependent upon the angle of internal friction (ϕ). The curve is based on Meyerhoff bearing capacity factors for deep foundations and has been empirically modified to reflect the performance of foundation anchors. Effective overburden pressure (q) is determined by multiplying a given soil’s effective unit weight (γ) times the vertical depth (d) of that soil as measured from the surface to the helix.

For multiple soil layers above a given helix, effective overburden pressure may be calculated for each layer and then added together (see Design example, pages 8 and 9).

When c and ϕ for a given soil are both known, $(9c + q N_q)$ can

be solved directly. However, soil reports often do not contain enough data to determine values for both c and ϕ . In such cases, Equation B must be simplified to arrive at an answer.

The design professional must decide which soil type (cohesive or cohesionless) is more likely to control ultimate capacity. Once this decision has been made, the appropriate part of the $(9c + q N_q)$ term may be equated to zero, which will allow solution of the equation. This approach generally provides conservative results. When the soil type or behavior expected cannot be determined, calculate for both behaviors and choose the smaller capacity.

Tension anchor capacities are calculated by using average parameters for the soil above a given helix. Compression capacities may be calculated similarly, however soil strength parameters should be averaged for the soil below a given helix.

We recommend the use of field testing to verify the accuracy of theoretically predicted foundation anchor capacities.

INSTALLATION TORQUE VS. ANCHOR CAPACITY

Holding strength related to installing torque

The idea that the amount of torsional force required to install a foundation anchor relates to the ultimate capacity of the foundation in tension or compression has long been promoted by A.B. Chance. Precise definition of the relationship for all possible variables remains to be achieved. However, simple empirical relationships have been used for a number of years.

Recommended reading on

the subject is in the paper "Uplift Capacity of Helical Anchors in Soil" by R.M. Hoyt and S.P. Clemence (Bulletin 2-9001). It gives the formula for the torque/anchor capacity as:

$$Q_u = K_t \times T$$

where

Q_u = ultimate uplift capacity [lb. (kN)]

K_t = empirical torque factor [ft.⁻¹ (m⁻¹)]

T = average installation torque [ft.-lb. (kN-m)]

The value of K_t may range from 3 to 20 ft.⁻¹ (10 to

66 m⁻¹), depending on soil conditions and anchor design (principally the shaft size). For Type SS foundation anchors, it typically ranges from 10 to 12 (33 to 39) with 10 (33) being the recommended default value. For Type HS foundation anchors, the recommended default value is 7 (23). The same values of K_t are used for both tension and compression loading. Torque monitoring tools are available from Chance. Their use provides a good method of production control during installation.

**Type SS HELICAL PIER® Foundation Systems
Installation Torque vs. N-Value
in Sand**

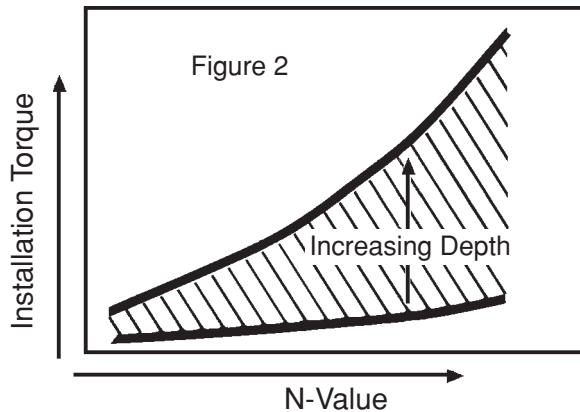

**Type SS HELICAL PIER® Foundation Systems
Installation Torque vs. N-Value
in Clay**

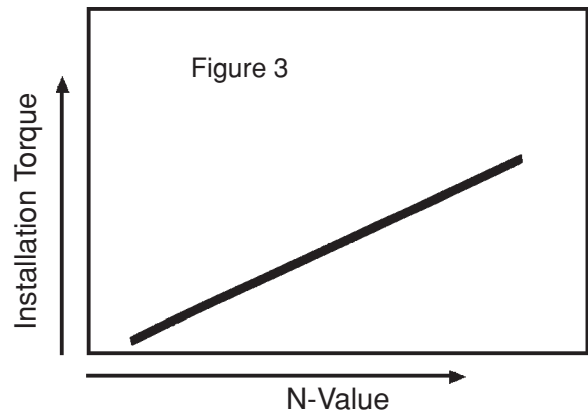

Figures 2 and 3 show graphs depicting how installation torque varies with respect to SPT results (N-values per ASTM D-1586) indicating the in-situ soil strength.

Figure 2 shows the relationship between installation torque and N-values for sands. The envelope of curves depicts increasing torque for a given N value with increasing depth. Water table position directly affects installation torque and ultimate capacity by causing a reduction in the effective unit weight of the soil below the table. This in turn will cause a reduction in installation torque and ultimate capacity.

For cohesive soil (Figure 3), a straight-line relationship is provided as soil strength or cohesion is the only factor affecting installation torque and ultimate capacity.

PRODUCT SPECIFICATION

System Ratings Table		Helical Pier Foundation Systems Family			
		SS5 Square Shaft 1½" (3.8 cm)	*SS150 Square Shaft 1½" (3.8 cm)	SS175 Square Shaft 1¾" (4.4 cm)	HS Pipe Shaft 3½" (8.9 cm) OD
		Column 1	Column 2	Column 3	Column 4
Minimum Ultimate Torque Capacity [ft.-lb. (kN-m)]	Row A	5,500 (7.5)	7,000 (9.5)	10,000 (13.5)	11,000 (15)
Ultimate Strength [kips (kN)] for Axially Loaded Foundation Torque Limited	Row B	70 (310)	70 (300)	100 (440)	100 (440)
Working Capacity [kips (kN)] with 2.0 Safety Factor Torque Limited	Row C	35 (160)	35 (150)	50 (220)	50 (220)
Ultimate Strength per Helix - Tension/Compression [kips (kN)]	Row D	⁽²⁾ 40 (180)	⁽²⁾ 40 (180)	⁽²⁾ 50 (220)	⁽²⁾ 50 (220)
Working Capacity per Helix - Tension/Compression [kips (kN)] with 2.0 Safety Factor	Row E	⁽¹⁾⁽²⁾ 20 (90)	⁽²⁾ 20 (90)	⁽²⁾ 25 (110)	⁽²⁾ 25 (110)

Bracket C150-0121

Min. Ultimate Strength [kips (kN)]	Row F	40 (180)	40 (180)	N/A	N/A
Working Capacity [kips (kN)] with 2.0 Safety Factor	Row G	20 (90)	20 (90)	N/A	N/A
Typical Achievable Installed Capacity [kips (kN)] ⁽⁴⁾	Row H	20 (90)	25 (110)	N/A	N/A

Bracket C150-0298

Min. Ultimate Strength [kips (kN)]	Row I	80 (360)	80 (360)	N/A	N/A
Working Capacity [kips (kN)] with 2.0 Safety Factor	Row J	40 (180)	40 (180)	N/A	N/A
Typical Achievable Installed Capacity [kips (kN)] ⁽⁴⁾	Row K	20 (90)	25 (110)	N/A	N/A

Bracket C150-0299

Min. Ultimate Strength [kips (kN)]	Row L	N/A	N/A	80 (360)	N/A
Working Capacity [kips (kN)] with 2.0 Safety Factor	Row M	N/A	N/A	40 (180)	N/A
Typical Achievable Installed Capacity [kips (kN)] ⁽⁴⁾	Row N	N/A	N/A	30 (130)	N/A

Bracket C150-0147

Min. Ultimate Strength [kips (kN)]	Row O	N/A	N/A	80 (360)	N/A ⁽³⁾
Working Capacity [kips (kN)] with 2.0 Safety Factor	Row P	N/A	N/A	40 (180)	N/A ⁽³⁾
Typical Achievable Installed Capacity [kips (kN)] ⁽⁴⁾	Row Q	N/A	N/A	40 (180)	N/A ⁽³⁾

*SS150 shafts have a paint stripe at top to distinguish from Type SS5.

⁽¹⁾For 14" (36 cm)-dia. foundation anchors, reduce allowable capacity by 20% per building code requirements. Not applicable to HS.

⁽²⁾For 14" (36 cm)-dia. helices, reduce ultimate capacity by 20%.

⁽³⁾Determined by bracket and haunch design.

⁽⁴⁾The capacity of Chance Helical Pier Foundation Systems is a function of many individual elements including the capacity of the foundation, bracket, anchor shaft, helix plate and bearing stratum, as well as the strength of the foundation-to-bracket connection and the quality of anchor installation. This row of the table shows typical achievable capacities under normal conditions. Actual achievable capacities could be higher or lower depending on the above factors.

PRODUCT SPECIFICATION (continued)

Lead and extension section lengths

Helical Pier Foundation Systems standard lead-section lengths are 5, 7, and 10 ft. (1.5, 2 and 3 m). The standard extension section lengths are 3½, 5, 7, and 10 ft. (1, 1.5, 2 and 3 m). These combinations of leads and extensions provide for a variety of installed foundation anchor lengths.

Helix areas

Standard diameters for helices manufactured by Chance are:

6 in. = 26.7 sq. in. (15 cm = 0.0172 m ²)
8 in. = 48.4 sq. in. (20 cm = 0.0312 m ²)
10 in. = 76.4 sq. in. (25 cm = 0.0493 m ²)
12 in. = 111 sq. in. (30 cm = 0.0716 m ²)
14 in. = 151 sq. in. (35 cm = 0.0974 m ²)

Helix configuration

Standard helices are ⅜ inch (0.95 cm) thick steel plates with outer diameters of 6, 8, 10, 12 and 14 inches (15, 20, 25, 30 and 35 cm). The lead section, or first section installed into the soil always contains helix plate(s). Extensions may be plain or helixed. Multihelix foundations have more than

one helix arranged in increasing diameters from the foundation tip to the uppermost helix. The nominal spacing between helix plates is three times the diameter of the next lower helix. For example, a Helical Pier Foundation Systems anchor with an 8-, 10-, and 12-inch (20, 25 and 30 cm) helix combination has a 24-inch (61 cm) space between the 8- and 10-inch (20 and 25 cm) helix and a 30-inch (76 cm) space between the 10- and 12-inch (25 and 30 cm) helix. Extensions with helix plates can be added to the foundation if more bearing area is required. They should be installed immediately after the lead section.

Capacities listed in the Ratings Table on the page 6 are mechanical ratings. One must be aware that the actual installed load capacities are dependent on actual soil conditions at each specific project site. Therefore, the design professional should use the bearing capacity method in designing anchor foundations. The number of helices, their size, and depth below grade is determined by obtaining soil

Minimum anchor type required based on mechanical ratings

Design Load, kips (kN)	Minimum Helical Pier Foundation Systems Anchor Required
0 to 25 (0 to 110)	SS5
25 to 35 (110 to 150)	SS150
35 to 50 (150 to 220)	SS175 or HS

Note: This chart uses a factor of safety vs. ultimate capacity = 2.

shear strength factors, cohesion (c) and angle of internal friction (Ø), and applying them as outlined in Theory of Foundation Anchor Design. The anchor family specified is based on the rated load carrying capacities for the specific foundation shaft size and installation torque required to install the foundation. The shaft sizes are 1½- or 1¾-inch (3.8 or 4.5 cm) square solid steel or 3½-inch (8.9 cm) OD heavy-wall steel pipe.

A.B. Chance assistance is available to aid the design professional in determining the best helix combination/foundation anchor family for a given application. Additional design considerations are as follows:

Corrosion

Corrosion of foundation anchors is a major consideration in permanent structures. That is why foundation components are hot-dip galvanized per ASTM A153. The zinc coating will add between 5% and 20% to the life of Helical

Pier Foundation Systems anchors. The Federal Highway Administration (FHWA-SA-96-072) has established, from an extensive series of field tests on metal pipes and sheet steel buried by the National Bureau of Standards, maximum corrosion rates for steel buried in

soils exhibiting the electrochemical index properties shown in the table:

The corrosion rates shown below are suitable for

designs for screw anchor foundations. These rates of corrosion assume a mildly corrosive in-situ soil environment having the electrochemical property limits that are listed in table below. The design corrosion rates, per FHWA-SA-96-072, are:

For Zinc
15 µm/year (first 2 years)
4 µm/year (thereafter)

For Carbon Steel
12 µm/year

For example, in a soil

Property	Criteria	Test Method
Resistivity	>3000 ohm-cm	AASHTO T-288-91
pH	>4.5<9	AASHTO T-289-91
Chlorides	<100 PPM	AASHTO T-291-91
Sulfates	<200 PPM	AASHTO T-290-91
Organic Content	1% max.	AASHTO T-267-86

PRODUCT SPECIFICATION (continued)

environment that meets the electrochemical properties listed in the table, the allowable strength of the galvanized SS5 screw anchor foundation for a design life of 75 years, is 37 kips (160 kN). For soils with

corrosion potential different than that stated above, one should consult a corrosion engineer.

Chance Bulletin 01-9204 contains extensive data taken from NBS circular 579, April

1957, by Melvin Romanoff. The reader is encouraged to obtain this bulletin for more reference and examples on corrosion, including methods of additional corrosion protection.

Slenderness ratio/buckling

It is intuitively obvious that Helical Pier Foundation Systems anchors have slender shafts. Very high slenderness ratios (Kl/r) can be expected depending on the length of the foundation. This condition would be a concern if the foundation were a column in air or water and subjected to a compressive load. However, the foundations are not supported by air or water, but by soil. Therein lies the reason

that foundations can be loaded in compression up to their rated load capacities.

As a practical guideline, when a specific soil's Standard Penetration Test blow count data per ASTM D-1586 is greater than 4, buckling of the foundation shaft has been found not to occur when loaded to the rated capacities.

Buckling analysis for soils having lower blow counts can be done by hand calculations with the *Davisson (1963)

Method, or by computer solution with a finite difference method such as that used in the program LPILE (ENSOFT, Austin, TX). Research by Chance Co. and others ([†]Hoyt, et al, 1995) has shown that buckling is a practical concern only in the softest soils (very soft and soft clay, very loose sands) and this is in agreement with past analyses and experience on other types of pile foundations. Refer to Chance Bulletin 01-9605 for more details.

Design example

An existing two-story brick-veneer residence has experienced settlement. The designer has calculated a foundation load of 1500 pounds per linear foot (22 kN per meter). In addition, the designer has determined the best foundation anchor spacing is 6 feet (1.8 m) on centers. Thus, the design load is 9 kips (40 kN) per anchor. Soil properties are listed below. Determine the number and size of helix(es) required, their depth below grade, and the foundation anchor family needed to carry the design load of 9 kips (40 kN). Use a safety factor (SF) of

2.

Soil Properties (as determined from soil boring data):

5½ feet (1.7 m) of sandy clay fill overlying homogeneous sand material having soil parameters of:

phi (ϕ) of sand = 34°

unit weight (γ) of sand = 120 lb./ft.³ (19 kN/m³); sandy clay = 103 lb./ft.³ (16 kN/m³)

Water table at 18 ft. depth.

- Using the standard bearing equation:

$$Q_h = A_h (9c + qN_q)$$

For sand, the bearing equation reduces to:

$$Q_h = A_h (qN_q)$$

From Figure 1 at the end of Theory of Foundation Anchor Design, choose the bearing capacity factor:

$$N_q = 22 \text{ For } \phi (\phi) = 34^\circ$$

- At this point, an iterative process is required. Select a helix combination you believe can develop the required load.
- Trial 1: Select a single helix foundation anchor [10" (25 cm) diameter helix].

Determine vertical depth to the helix. In this example, it is desired to install the helix into the homogeneous sand well below the fill material. Applica-

*Davisson, M.T. 1963. "Estimating Buckling Loads for Piles." Proc. 2nd Pan-Amer. Conf. on S.M. & F.E., Brazil, vol. 1: 351-371.

[†]Hoyt, R.M., et al 1995. "Buckling of Helical Anchors Used for Underpinning", Proc. Foundation Upgrading and Repair for Infrastructure Improvement, San Diego.

PRODUCT SPECIFICATION (continued)

Design example (continued)

tion guideline No. 4 from page 10 requires at least 3 helix diameters. Therefore, the helix [10" (25 cm) dia.] should be at least $5\frac{1}{2}$ ft. + 30 inches = 8 ft. (1.7 m + 0.7 m = 2.4 m)

Calculate effective overburden pressure for the 10" (25 cm) helix.

$$q = \gamma \times d$$

$$q_{10} = (0.103 \times 5.5) + (0.120 \times 2.5) = 0.867 \text{ ksf}$$

$$[q_{10} = (16 \times 1.7) + (19 \times 0.76) = 42 \text{ kN/m}^2]$$

Determine the capacity of the helix using reduced bearing equation.

$$Q_h = A_h (qN_q)$$

$$A_{10} = 76.4 \text{ in.}^2 (0.0493 \text{ m}^2)$$

(see "Helix areas" on page 7)

$$Q_{10} = (76.4/144) \times 0.867 \times 22 = \underline{10.12 \text{ kips}}$$

$$Q_{10} = 0.0493 \times 42 \times 22 = \underline{45 \text{ kN}}$$

Ultimate theoretical capacity = 10.12 kips (45kN)

Another trial is required because the design load of 9 kips (40 kN) times a Safety Factor of 2 = 18 kips (80 kN) > 10.12 kips (45kN).

- **Trial 2:** Select a 12" (30 cm) dia. foundation anchor installed 2 feet (0.6 m) deeper into the sand.

$$d_{12} = 8 \text{ ft.} + 2 \text{ ft.} = 10 \text{ ft.}$$

$$[d_{12} = 2.4 \text{ m} + 0.6 \text{ m} = 3.0 \text{ m}]$$

$$q_{12} = (0.103 \times 5.5) + (0.120 \times 4.5) = 1.107 \text{ ksf}$$

$$[q_{12} = (16 \times 1.7) + (19 \times 1.3) = 52 \text{ kN/m}^2]$$

$$A_{12} = 111 \text{ in.}^2 (0.0716 \text{ m}^2)$$

$$Q_{12} = (111/144) \times 1.107 \times 22 = \underline{18.77 \text{ kips}}$$

$$[Q_{12} = 0.0716 \times 52 \times 22 = \underline{82 \text{ kN}}]$$

Ultimate theoretical capacity = 18.77 kips (82 kN)

9 kips (40 kN) times SF of 2 = 18 kips (80 kN)
< 18.77 kips (82 kN).

Thus, a 12" (30 cm) diameter foundation anchor with the helix 10 ft. (3 m) below the surface will work.

- **Feasibility check:**

Application guideline No. 8 from page 10 recommends that economic feasibility should be checked if more than one

combination of foundation lead and extension sections can be used. Therefore, an 8"-10" (20 cm - 25 cm) two-helix foundation will be considered for this example: The top helix [10" (25 cm) dia.] should be at least 8 ft. (2.4 m) for reasons explained previously. Remember the helices are spaced 3 diameters apart. So 8" (20 cm) x 3 = 24 inches (0.6 m). Thus, the vertical distance to each helix is:

$$d_{10} = 5.5 \text{ ft.} + (3 \times 10) \text{ in.} = 8 \text{ ft.}$$

$$[d_{10} = 1.7 \text{ m} + 3(25 \text{ cm}) = 8 \text{ ft.}]$$

$$d_8 = 8 \text{ ft.} + (3 \times 8) \text{ in.} = 10 \text{ ft.}$$

$$[d_8 = 2.4 \text{ m} + 3(20 \text{ cm}) = 3 \text{ m}]$$

Calculate effective overburden pressure for each helix.

$$q = \gamma \times d$$

$$q_{10} = (0.103 \times 5.5) + (0.120 \times 2.5) = 0.867 \text{ ksf}$$

$$[q_{10} = (16 \times 1.7) + (19 \times 0.76) = 42 \text{ kN/m}^2]$$

$$q_8 = (0.103 \times 5.5) + (0.120 \times 4.5) = 1.107 \text{ ksf}$$

$$[q_8 = (16 \times 1.7) + (19 \times 1.3) = 52 \text{ kN/m}^2]$$

Determine the capacity of each helix using reduced bearing equation and sum for resulting ultimate theoretical anchor capacity.

$$Q_h = A_h (qN_q)$$

$$A_8 = 48.4 \text{ in.}^2 (0.0312 \text{ m}^2)$$

$$Q_{10} = (76.4/144) \times 0.867 \times 22 = \underline{10.12 \text{ kips}}$$

$$[Q_{10} = 0.0493 \times 42 \times 22 = \underline{46 \text{ kN}}]$$

$$Q_8 = (48.4/144) \times 1.107 \times 22 = \underline{8.19 \text{ kips}}$$

$$[Q_8 = 0.0412 \times 52 \times 22 = \underline{36 \text{ kN}}]$$

Ultimate theoretical capacity = 18.31 kips
(82 kN)

Thus, an 8"-10" (20 cm - 25 cm) diameter foundation anchor with the top helix 8 ft. (2.4 m) below the surface will also work. The best choice will have to be made based on total installed cost.

- **Select the appropriate foundation anchor family:**

Because this is an underpinning retrofit job, check the Foundation System Ratings Table to select the appropriate

foundation anchor family. From Row D, Column 1 of the Table, an SS5 series 1½" (3.8 cm) square shaft foundation's rated capacity is 20 kips (90 kN), which exceeds the design load of 9 kips (40 kN).

- **Check helix ratings:**

Based on Row B, Column 1 of the Ratings Table, the allowable capacity of an SS5 foundation anchor with a single helix is 20 kips (90 kN), which exceeds the design load. Therefore, a single helix foundation can be used.

- **Check the installation torque required to ensure adequate capacity:**

Torque required = Required Load/ K_t

$$\underline{18,000 \text{ lb.}} = 1,800 \text{ ft.-lb.}$$

$$10$$

$$\underline{80 \text{ kN}} = 2.4 \text{ kN-m}$$

$$33 \text{ m}^{-1}$$

Based on Row A, Column 1 of the Ratings Table, the allowable torque capacity of an SS5 foundation anchor is 5,500 ft.-lb. (7.5 kN-m), which exceeds the 1,800 ft.-lb. (2.4 kN-m) required torque.

Per application guideline No. 9 from page 10, if a stronger or denser stratum overlaid the sand, it would be necessary to check the installing torque in this stratum to be sure the anchor could be installed.

For additional reference, Chance Bulletin 31-8901 contains example problems for tension anchors in both cohesive and cohesionless soils.

PRODUCT SPECIFICATION (continued)

Application guidelines

1. Foundation anchors should be applied as deep foundations. The vertical distance between the uppermost helix and the soil surface should be no less than 5 feet (1.5 m) or 5 times the helix diameter.

2. Installation torque should be averaged over the last three diameters of embedment of the largest helix. This will provide an indication of the anchor's capacity based on the average soil properties throughout the zone that will be stressed by the foundation.

3. The uppermost helix should be installed at least three diameters below the depth of seasonal variation in soil properties.

4. The uppermost helix should be installed at least three helix diameters into competent load-bearing soil.

5. For a given foundation length, it is better to use a few long extensions than many shorter extensions. This results in fewer connections in the soil.

6. Foundation anchors should be spaced laterally no closer than three diameters on centers. A better spacing is five diameters. Use the largest helix

diameter in making the spacing determination.

The influence of the structure's existing foundation on the foundation anchor also should be considered.

8. Check economic feasibility if more than one combination of foundation lead and extension sections can be used.

9. If any stronger, denser, etc. stratum overlies the bearing stratum, check installation torque in the stratum to ensure anchor can be installed to final intended depth without torsional overstressing.

Specification References

Details on the Chance Helical Pier Foundation Systems are available upon request in the three-part section Manu-Spec[®] format (of the Spec-Data[®] program copyrighted by The Construction Specifications Institute). Filed under the identical 02150 designation as Sweet's, highlights include:

Part 1 — General

1.01 Summary: New and remedial building foundation reinforcement and stabilization, retaining walls, tieback systems. Related sections: Excavating to working level, load tests, cast-in-place concrete reinforcement. Pricing.

1.02 References: Thirteen ASTM and one SAE standards specifications.

1.03 Definition of system

1.04 System description

1.05 Submittals: Conditions of the Contract, Spec-Data[®], shop drawings, certified test reports and installation instructions. Closeouts: Warranty, project records.

1.06 Quality Assurance: Dealer certification, preinstallation meetings.

1.07 Warranty: Project, manufacturer, period (term).

Part 2 — Products

2.01 Shoring and underpinning: Chance; proprietary system.

2.02 Product substitutions: None.

2.03 Manufactured components: Screw anchor plate, shaft, bolts, steel bracket.

2.04 Source quality: Tests, inspections, verification of performance.

Part 3 — Execution

3.01 Manufacturer's instructions: Comply with technical data.

3.02 Preparation: Spare nearby structures; varying elevations.

3.03 Installation: Certified installer; power units; torque recording; alignment; adapters; down pressure; rate of rotation; obstructions; minimum depth, torque and cover, A/E approval, connect to structure.

Light Duty Bracket

Primarily for correcting sagging, lesser loads; affordable "quick fix" outlasts the porches, stairways, decks and patios it repairs.

SS5, SS150, SS175 Underpinning Brackets

Applied in multiple locations along the foundation to stabilize and correct problems caused by poor soil conditions.

For seismic uplift loads, the Uplift Restraint Bracket may be added.

Heavy Duty Bracket

For such higher loads as commercial buildings and larger residences. Applied in multiples to stop settled areas, resist new movement.

All components are hot-dip galvanized to increase product life in aggressive soils.



PRODUCT SPECIFICATION (continued)



Uplift Restraint Bracket

For seismic conditions and to resist other upward forces. Shown as applied, assembled to top of Standard-Duty Bracket.

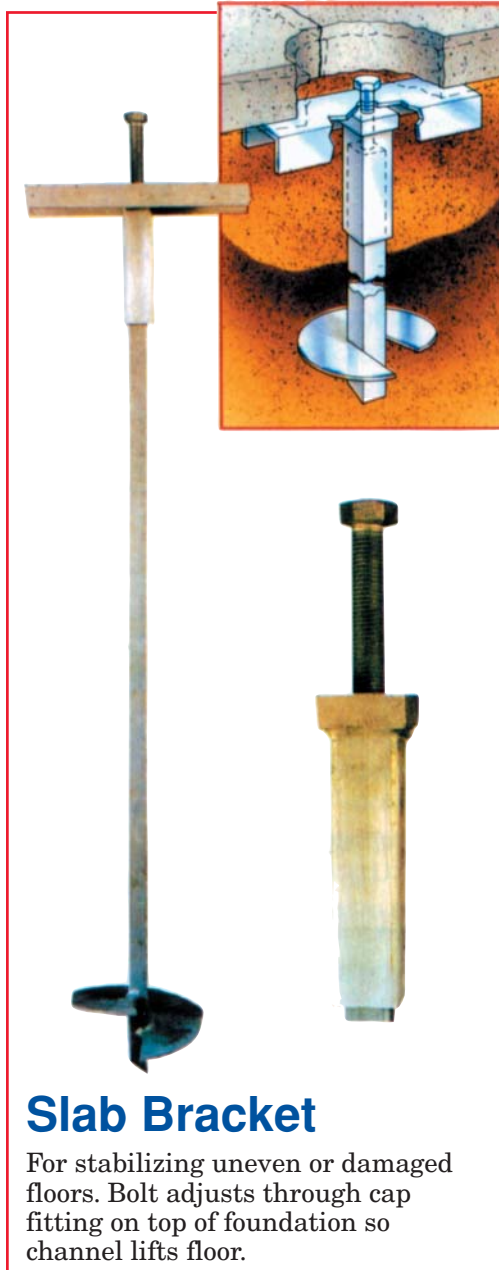

Slab Bracket

For stabilizing uneven or damaged floors. Bolt adjusts through cap fitting on top of foundation so channel lifts floor.

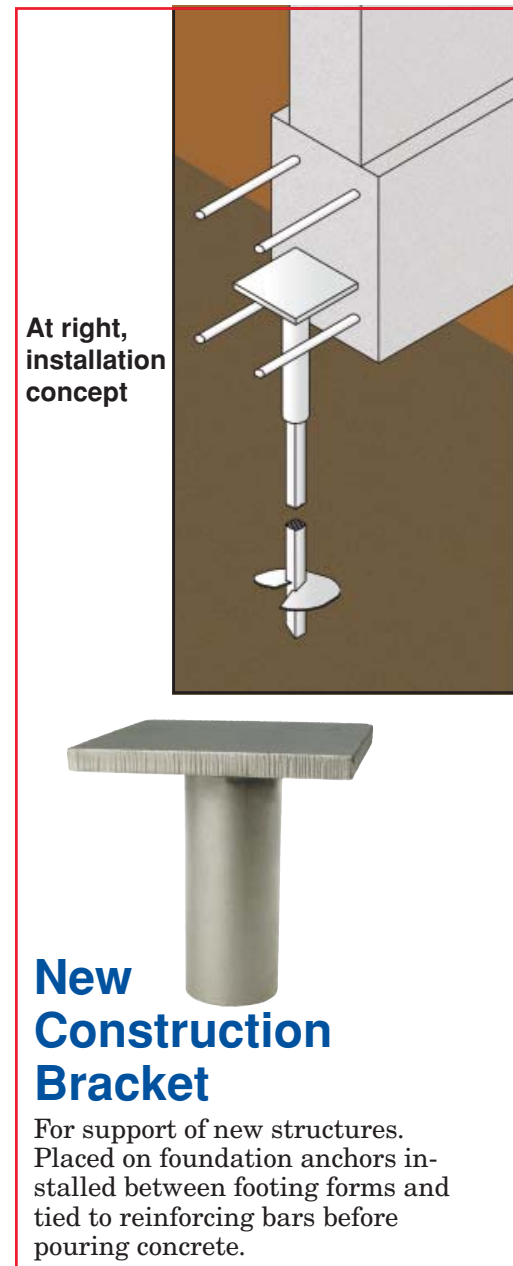

New Construction Bracket

For support of new structures. Placed on foundation anchors installed between footing forms and tied to reinforcing bars before pouring concrete.

Wall Anchors

To restrain movement in foundation walls. Through a hole drilled in wall, a rod threads into an anchor plate installed into the soil bank. A ribbed retainer plate and a nut secure the rod inside the wall. Either of two methods may be used to stabilize, or often to straighten, failing walls.

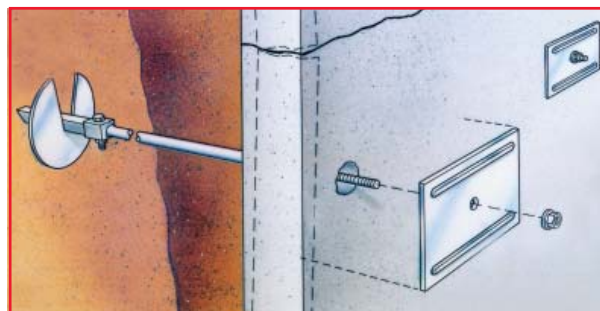

At left, screw anchors tieback retaining and foundation walls.

Dura-Grip® Wall Repair System cross plate anchors tieback retaining and foundation walls.

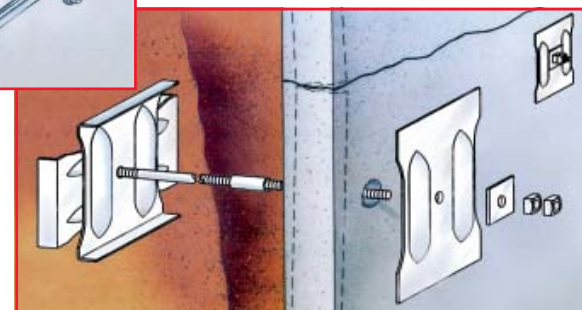

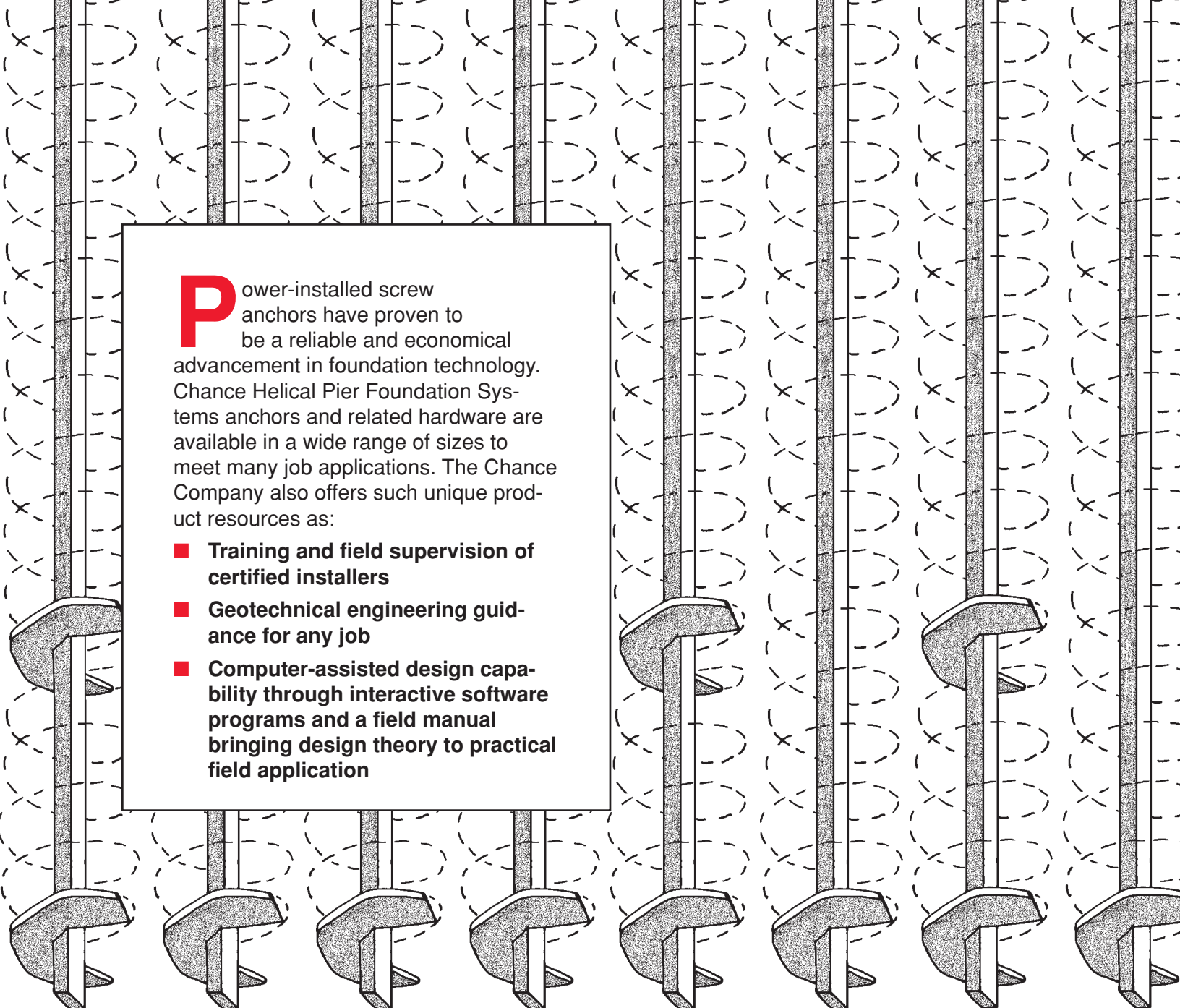

Power-installed screw anchors have proven to be a reliable and economical advancement in foundation technology. Chance Helical Pier Foundation Systems anchors and related hardware are available in a wide range of sizes to meet many job applications. The Chance Company also offers such unique product resources as:

- Training and field supervision of certified installers
- Geotechnical engineering guidance for any job
- Computer-assisted design capability through interactive software programs and a field manual bringing design theory to practical field application

DISCLAIMER: The material presented in this bulletin is derived from generally accepted engineering practices. Specific application and plans of repair should be prepared by a local structural/geotechnical engineering firm familiar with conditions in that area. The possible effects of soil (such as expansion, liquefaction and frost heave) are beyond the scope of this bulletin and should be evaluated by others. Chance Company assumes no responsibility in the performance of anchors beyond that stated in our SCS policy sheet on terms and conditions of sale.

NOTE: Because Hubbell has a policy of continuous product improvement, we reserve the right to change design and specifications without notice.



CHANCE[®]
www.abchance.com

**A.B. Chance, a Division of
Hubbell Power Systems, Inc.**
210 North Allen Street
Centralia, MO 65240 USA

Printed in USA
©2004 Hubbell, Inc.

Bulletin 01-9601
Revised 10/04 5M10/4A&J